

ITASHADES

design | Lorenzo Bertocco





The lampshade with a more contemporary take. Technological innovation has made it possible for us to move the light-source from the center of a lamp to its perimeter. This simple opportunity has given us the chance to create a new archetype for the traditional lampshade, a very low profile and a very lightweight look as the center of the shade can be hollow and freed of all technical limitations previously imposed by lamp technology. The result is an object that is distinguished by its simplicity and purity that declares its hi-tech personality once illuminated.

*Il paralume rivisitato in chiave contemporanea
L'innovazione tecnologica ha reso possibile lo spostamento della sorgente luminosa dal centro della lampada al perimetro della stessa. Questo semplice gesto ha dato forma a un nuovo archetipo del classico paralume in tessuto di altezza molto contenuta in cui il centro viene liberato da qualsiasi elemento tecnico. Il risultato è un oggetto che si distingue per la sua semplicità e purezza formale che dichiara il suo carattere hi-tech una volta illuminato.*

All models have a prismatic PMMA cover.

This element shields the light source and diffuses the light uniformly upwards, it also prevents dust accumulating in the fitting.

Tutti i modelli, hanno una copertura in PMMA prismatico. Questo elemento oltre a chiudere la parte superiore della lampada impedendo che si accumuli lo sporco, schermo la sorgente luminosa e diffonde la luce in modo uniforme verso l'alto.



ITASHADES

collection

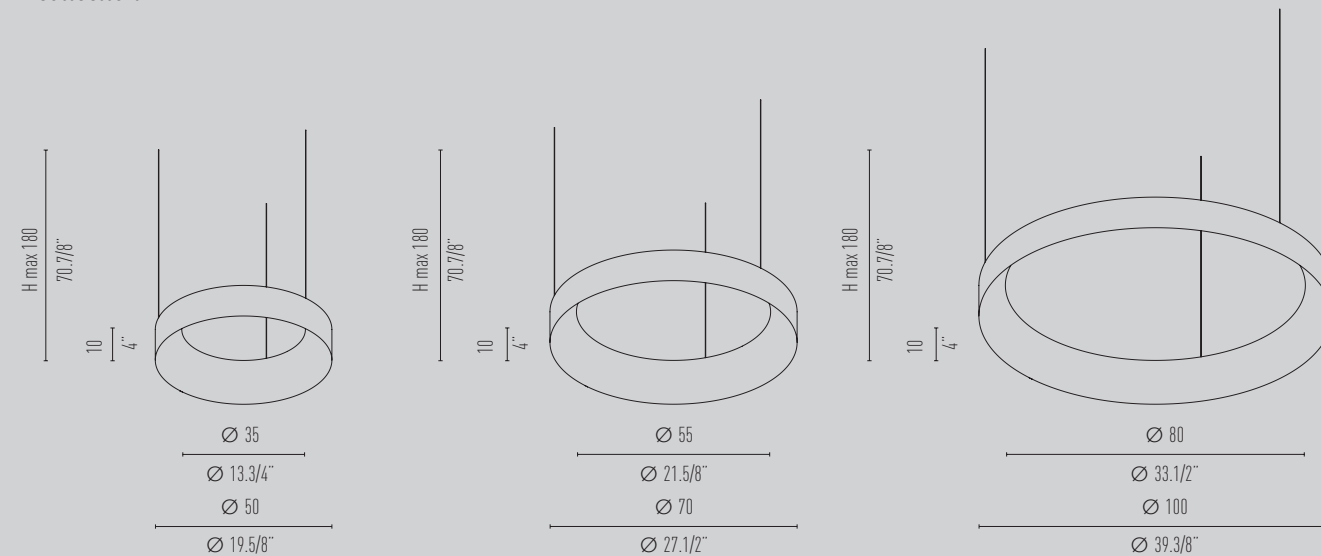

SUSPENSION CY 50



Lamp / 24W LED 3000°K LM3390

SUSPENSION CY 70



Lamp / 34W LED 3000°K LM4750

SUSPENSION CY 100



Lamp / 48W LED 3000°K LM6690

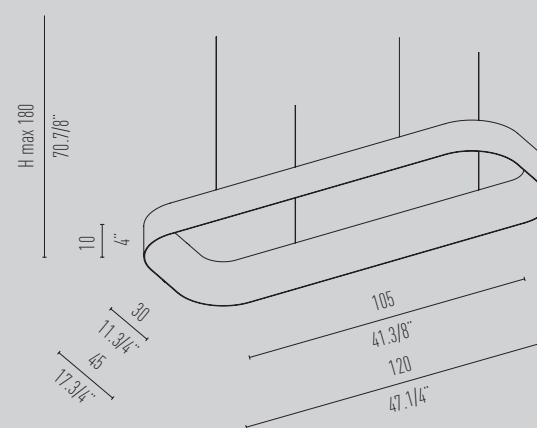

SUSPENSION RE 120



Lamp / 48W LED 3000°K LM7130

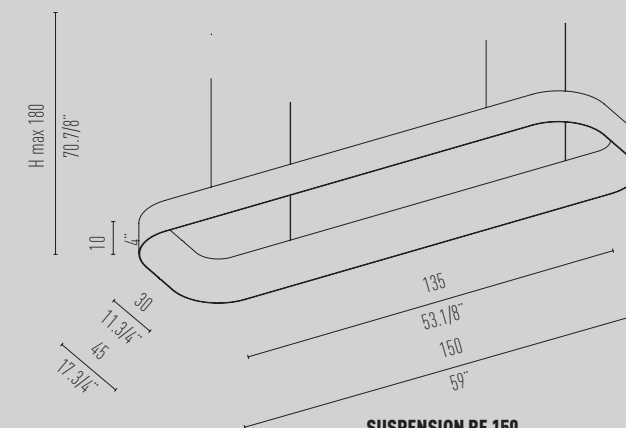

SUSPENSION RE 150



Lamp / 56W LED 3000°K LM8430

FABRIC / TESSUTO



MATERIAL

metal structure and fabric cover in prismatic PMMI
struttura in metallo e tessuto copertura in PMMA prismatico